



PRODUCTS CATALOG

ELECTRICAL ENCLOSURES & MODULAR CABINETS



20

exmweb.com

NEMA 12-13 ENCLOSURES

5500 DDS

OIL & DUST TIGHT DOUBLE DOOR ENCLOSURE

The 5500 DDS floor mounted double door, oil and dust tight enclosures are used indoors for protection against dirt, dust and oil. The box and cover are made of high quality code gauge steel, with all seams continuously welded. The opening has a curled lip around all sides, and there is no center post. The left hand door is flanged and the 3-point stainless steel pad-

lockable handle is on the right hand door. The captive pins of the concealed hinges can be easily pulled to remove the door. Floor mounting stands are provided, and body stiffeners are installed on larger models. **Each enclosure comes complete with a galvanized inner panel**, which mounts on welded M10 studs. The enclosure is finished with heat fused powder paint, electro-

statically applied on a pretreated base. Inner panel is galvanized. Box is ANSI/ASA 61 gray. **CSA Certified / UL Listed NEMA/EEMAC 1-3R*-12-13 IP55**

***Drain hole required**

Refer to p.734 to validate choice of substrate for the application

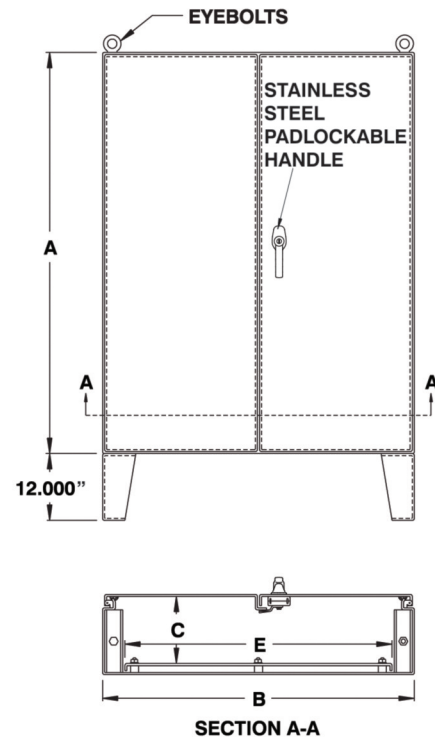
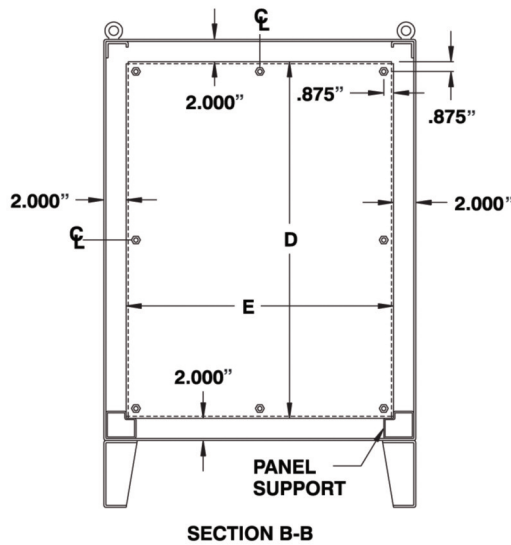

CATALOG NUMBER	DIMENSIONS					SHIP WGHT LBS.
	A	B	C	D	E	
5500 DDS604808	60	48	8	56	44	422
5500 DDS604810	60	48	10	56	44	433
5500 DDS606010	60	60	10	56	56	520
5500 DDS726010	72	60	10	68	56	608
5500 DDS727210	72	72	10	68	68	716
5500 DDS604812	60	48	12	56	44	463
5500 DDS606012	60	60	12	56	56	530
5500 DDS726012	72	60	12	68	56	633
5500 DDS727212	72	72	12	68	68	751
5500 DDS604816	60	48	16	56	44	523
5500 DDS606016	60	60	16	56	56	650
5500 DDS726016	72	60	16	68	56	740
5500 DDS727216	72	72	16	68	68	841
5500 DDS604820	60	48	20	56	44	589

